

## OCC myRIO 232 Serial Adapter User Manual

OCC Parts Covered: OCC-myRIO-232 and OCC-myRIO -232-kit

The OCC myRIO 232 Serial Adapter is a pcb designed specifically for the National Instruments myRIO product. It plugs into one of the MXP connectors of the myRIO and converts the serial port Tx and Rx pins on that connector to voltage levels that are compatible with most RS232 devices. (Although the myRIO serial ports are functional, the voltage levels of the Tx and Rx pins are 3.3V, rather than the 5 to 12 V most serial devices require. The Tx signal is on pin 14 of the MXP connector, and Rx is on pin 10. The myRIO 232 Serial Adapter also uses a small bit of the +5V power from the MXP connector. With the exception of the Tx and Rx pins, all other pins from the MXP connector are wired through to a compatible connector on the other side of the myRIO 232 Serial Adapter. Thus, all other functionality you may wish to use on the MXP connector is still available.

The serial port signals area wired to the 9pin dSub connector mounted on the top of the myRIO 232 Serial Adapter. This serial port is configured as a DTE (e.g. computer end). Thus, if you wish to communicate to a serial port on another computer or other DTE device, you will need to use a null modem. DCE devices (e.g. instruments) can be connected without a null modem. The pinouts for the 9pin dSub connector are shown below:

Pin	Function
1	n.c.
2	Rx
3	Tx
4	n.c.
5	gnd

6	n.c.
7	n.c.
8	n.c.
9	n.c.

Table 1. Serial Port pin-out, connector P2.

Note that no hardware handshaking lines are connected due to the fact that these functions are not supported by the myRIO.

The OCC myRIO 232 Serial Converter is compatible with baud rates up to 115,200. A green LED is connected to the Tx signal, and a yellow LED is connected to the Rx signal, for assistance in debugging your serial communication.

# OCC myRIO 232 Serial Converter Kit Assembly Guidelines

The OCC myRIO 232 Serial Converter is available as an assembled, tested product or as a kit. The board uses through-hole components for easy manual soldering of the components. When assembling the kit, standard precautions should be taken. The board schematic and layout are shown below for assistance with assembly of the kit.

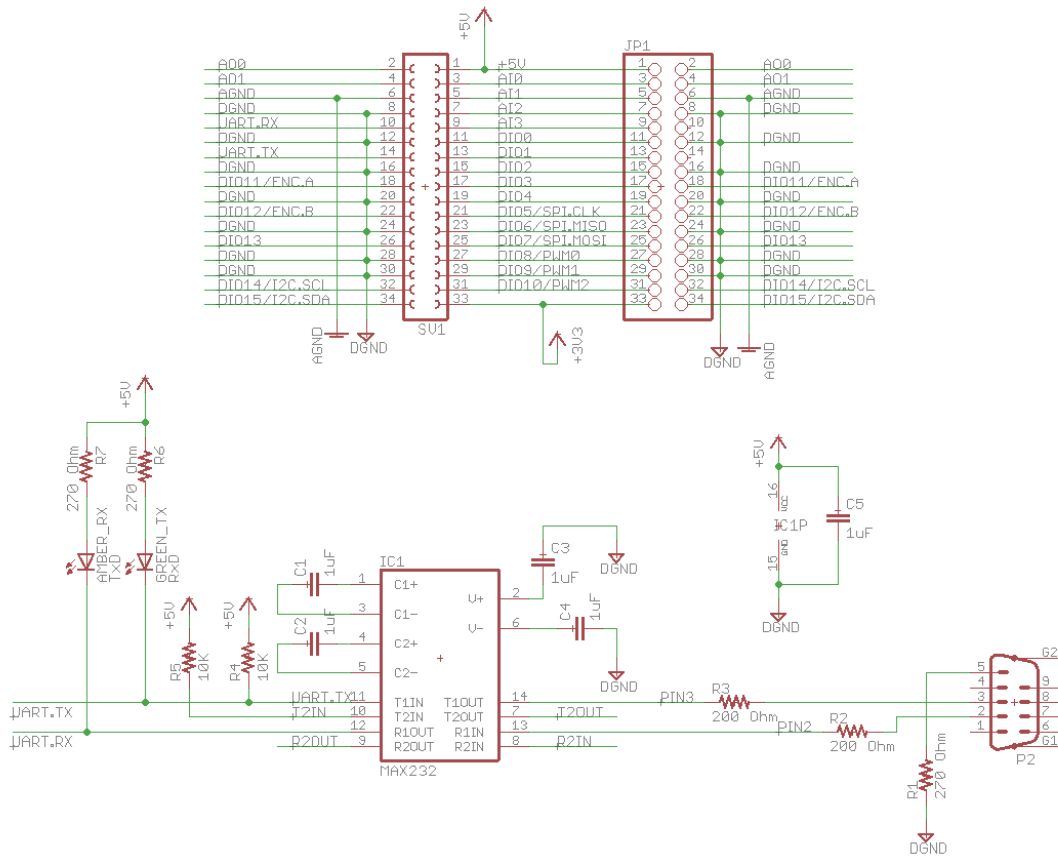

Figure 1, Schematic of the OCC myRIO 232 Serial Converter.

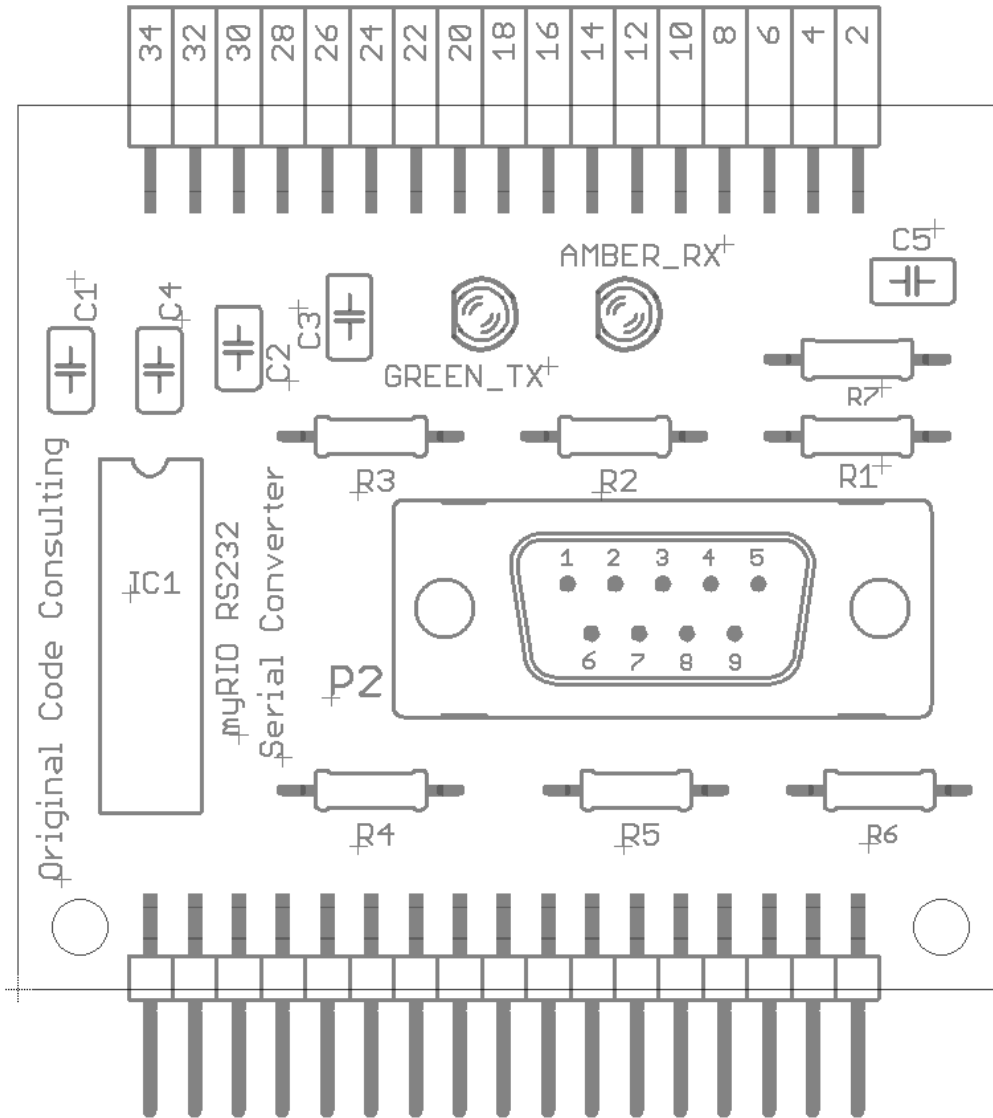

Figure 2, Board layout of the OCC myRIO 232 Serial Converter.

Copyright 2017 Original Code Consulting. All rights reserved.